



INSTALLATION, OPERATION & MAINTENANCE INSTRUCTIONS

1455 Kleppe Lane □ Sparks, NV 89431-6467 □ (775) 359-4712 □ Fax (775) 359-7424
E-mail: haws@hawsco.com □ website: www.hawsco.com

No. 0580001156 (3)

2RKHO.P / 2RKHO.H Dual Hands-Off Retro-Fit Kit

NOTE TO INSTALLER: Please leave this information with the Maintenance Department.

CAUTION! Prior to making any electrical connections, verify with a voltmeter that power from the service panel is **off**.

LIMITED WARRANTY

HAWS® warrants that this specific product is guaranteed against defective material or poor workmanship for a period of **one year from date of shipment**. HAWS liability under this warranty shall be discharged by furnishing without charge F.O.B. HAWS Factory any goods, or part thereof, which shall appear to the Company upon inspection to be of defective material or not of first class workmanship, provided that claim is made in writing to Haws within a reasonable period after receipt of the product. Where claims for defects are made, the defective part or parts shall be delivered to the Company, prepaid, for inspection. HAWS will not be liable for the cost of repairs, alterations or replacements, or for any expense connected therewith made by the owner or his agents, except upon written authority from HAWS, Sparks, Nevada. HAWS will not be liable for any damages caused by defective materials or poor workmanship, except for replacements, as provided above. Buyer agrees that HAWS shall not be liable for general, special, or consequential damages claimed to arise under the contract of sale. The drinking fountain manufactured by HAWS is warranted to function if installation and maintenance instructions provided are adhered to. The units also must be used for the purpose for which they were intended.

NO OTHER WARRANTIES EXPRESSED OR IMPLIED ARE AUTHORIZED, PROVIDED OR GIVEN BY HAWS.

SHOULD YOU EXPERIENCE DIFFICULTY WITH THE INSTALLATION OF THIS MODEL PLEASE CALL:

TECHNICAL SUPPORT: 1-800-766-5612

FOR CUSTOMER SERVICE: 1-888-640-4297

RECOMMENDED TOOLS: Spanner wrench (Haws pn 0006983506, not supplied) and Phillips head screwdriver.

MAINTENANCE: Periodically clean the strainer

INSTALLATION PROCEDURE

NOTES:

1. For all plastic push-in type fitting connections, only connect NSF-61 copper or plastic tubing. Stainless steel or glass tubing is not recommended. The following assembly instructions must be followed to ensure a watertight connection:
 - a. Cut tubing square and clean.
 - b. Mark from end of tube the length of insertion (See table below).
 - c. Push tube into the fitting until it bottoms out.
 - d. To remove, depress collet and pull tubing out.

Tube Sizes	O.D. Tolerance	Insertion Depth
3/8"	±.005"	3/4"

2. 2RKHO.P Transformer is compatible with Type A and Type B North American Electrical Outlets. For other receptacle types, an adapter must be provided by others.

STEP 1: Remove access plate. Turn off water supply. Disconnect tubing from 5874 Push Button and use Spanner Wrench (Haws pn 0006983506) to remove valve.

STEP 2: Flush water through supply lines thoroughly before installing the system. Do not allow dirt, Teflon tape, or metal particles to enter the solenoid valve.

STEP 3: Assemble in the following order:
Connect supply tubing to 3/8" OD Y-strainer inlet.
Use 3/8" OD tubing to connect Y-strainer outlet to solenoid valve inlet.
Use 3/8" OD tubing to connect solenoid valve outlet to regulator valve inlet.
Connect regulator valve inlet to bubbler tubing.
Reference plumbing drawing for installation instructions (see page 5 of 7).

STEP 4: Wire cable harness per Cable Wiring Schematic (see page 7 of 7).

STEP 5: Use sensor mounting hardware to secure sensors to holes for the 5874 Push Button.

STEP 6: For **2RKHO.P:** Plug the 9V transformer into a duplex receptacle. For **2RKHO.H:** Wire the transformer to appropriate power per NEC/CEC and Local Code. Please note that transformers must be installed such that they are protected from direct contact with water.

STEP 7: Clear the area in front the sensors. Allow the sensor to calibrate for at least 10 seconds before operating.

When the sensor is activated continuously for 30 seconds, the sensor will automatically shut off the water supply to the bubbler. To resume activation, remove obstruction and reactivate the sensor. This feature prevents flushing of water due to unintentional activation or vandalism.

STEP 8: Turn water supply on and adjust the bubbler's flow using the black regulator valve. Clockwise adjustment increases flow and counterclockwise decreases flow. Check fountain for leaks.

SENSOR/SOLENOID TROUBLESHOOTING	
PROBLEM	REPAIR CHECKLIST
1. Insufficient bubbler flow.	<ul style="list-style-type: none"> a. Check that screwdriver stop is wide open. Direction can be counterclockwise or clockwise depending on style of shut-off valve. b. Verify minimum 30 psi supply pressure. c. Clean inlet strainer (if one is present).
3. No bubbler flow – red light in the sensor does not flash once when user's hands are within the sensor's range	<ul style="list-style-type: none"> a. Unit is in Security Mode. b. Sensor is picking up reflections from a foreign object. Eliminate the source of reflection.
4. No bubbler flow – red light in the sensor flashes once when user's hands are within sensor range.	<ul style="list-style-type: none"> a. Connectors between electronic unit and solenoid are disconnected. Reconnect the connectors. b. Debris or scale in solenoid. Shut off water and power. Unscrew solenoid, pull out the plunger and spring from the solenoid and clean them. Use scale remover if needed. When replacing the plunger, ensure the spring is oriented vertically. c. The central orifice in the diaphragm is plugged or the diaphragm is torn. Clean the orifice or replace the diaphragm. d. The water supply pressure is higher than 115 psi. Reduce the supply water pressure.
4. Continuous bubbler flow – sensor flashes once when user's hands are within the sensor's range.	<ul style="list-style-type: none"> a. Debris or scale in solenoid diaphragm. Clean the orifice or replace diaphragm per 4b-c.
5. Continuous bubbler flow – red light in the sensor does not flash once when user's hands are within sensor range.	<ul style="list-style-type: none"> a. Sensor is dirty or covered. Clean or eliminate cause of interference. In this event, the security time will stop flow. b. Sensor is picking up reflections from the washbasin or another object. Decrease the range or eliminate the cause of reflection.
6. Repeated clogs in strainer.	<ul style="list-style-type: none"> a. Install water filter in supply line.
7. Bubbler does not activate.	<ul style="list-style-type: none"> a. Check wiring harness. Replace if necessary. b. Check solenoid valve. Replace if necessary. c. Replace sensor. d. Check transformer for 9V at output terminals; replace if necessary. e. Check splitter. Replace if necessary.

NOTES:

- 2RKHO.P AND 2RKHO.H RETROFIT KITS ALLOW THE FOLLOWING INDOOR FOUNTAINS TO BE CONVERTED FROM A HAWS 5874 PUSH BUTTON VALVE TO HANDS-OFF (TOUCHLESS) OPERATION:
 1001, 1001HPS, 1001HPSMS, 1001MS, 1011, 1011HPS, 1011HPSMS, 1011MS, 1025, 1025G, 1047, 1105, 1107L, 1109, 1109.14, 1117L, 1117LN, 1119, 1119.14
 H1001.8, H1001.8HPS, H1011.8, H1011.8HO, H1011.8HPS, H1107.8, H1109.8, H1117.8, H1119.8
 1920, 1920HPS, 1920W
 1311, 1409, 1430, 1431, 1435, 1441, 1501

FOUNTAINS (NOT SUPPLIED) MAY BE MOUNTED ON THE EXTERNAL WALL OF A BUILDING PROVIDED THE TRANSFORMER SHALL BE MOUNTED INSIDE THE WALL AND PROTECTED FROM WATER AS SHOWN IN THIS INSTALLATION PER NEC/CEC AND LOCAL CODE.

- RETROFIT KIT MODEL:
 2RKHO.P: INDOOR HO RETRO-FIT KIT (INCLUDES 2X HO SENSOR WITH MOUNTING HARDWARE, 2X SOLENOID VALVE, 2X REGULATOR, SPLITTER, AND 100-240V PLUG-IN TRANSFORMER - SEE SHEET 2).
 2RKHO.H: INDOOR HO RETRO-FIT KIT (INCLUDES 2X HO SENSOR WITH MOUNTING HARDWARE, 2X SOLENOID VALVE, 2X REGULATOR, SPLITTER, AND 100-277V HARDWIRE TRANSFORMER - SEE SHEET 3).
- 2RKHO.P REQUIRES 100-240VAC POWER CONNECTION. 2RKHO.H REQUIRES 100-277V POWER CONNECTION.
- TRANSFORMERS MUST BE MOUNTED SUCH THAT THEY ARE PROTECTED FROM WATER.
- 2RKHO.P TRANSFORMER IS COMPATIBLE WITH TYPE A AND TYPE B NORTH AMERICAN ELECTRICAL OUTLETS. FOR OTHER RECEPTACLE TYPES, AN ADAPTER (NOT SUPPLIED) MUST BE PROVIDED BY OTHERS.

(NOTES CONTINUED ON SHEET 4)

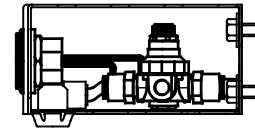

EXAMPLE 1920 BOTTLE FILLER INSTALLATION

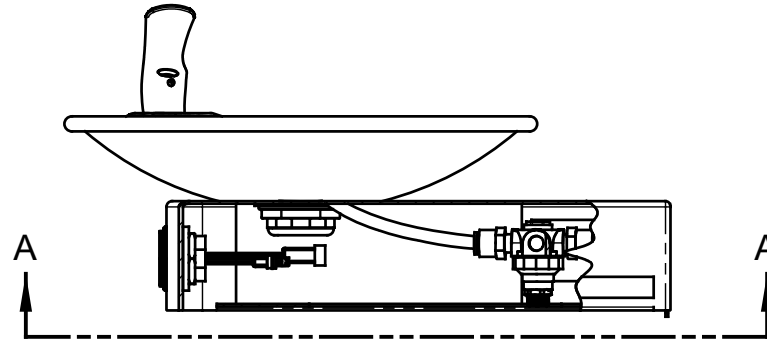

EXAMPLE 1011 FOUNTAIN INSTALLATION

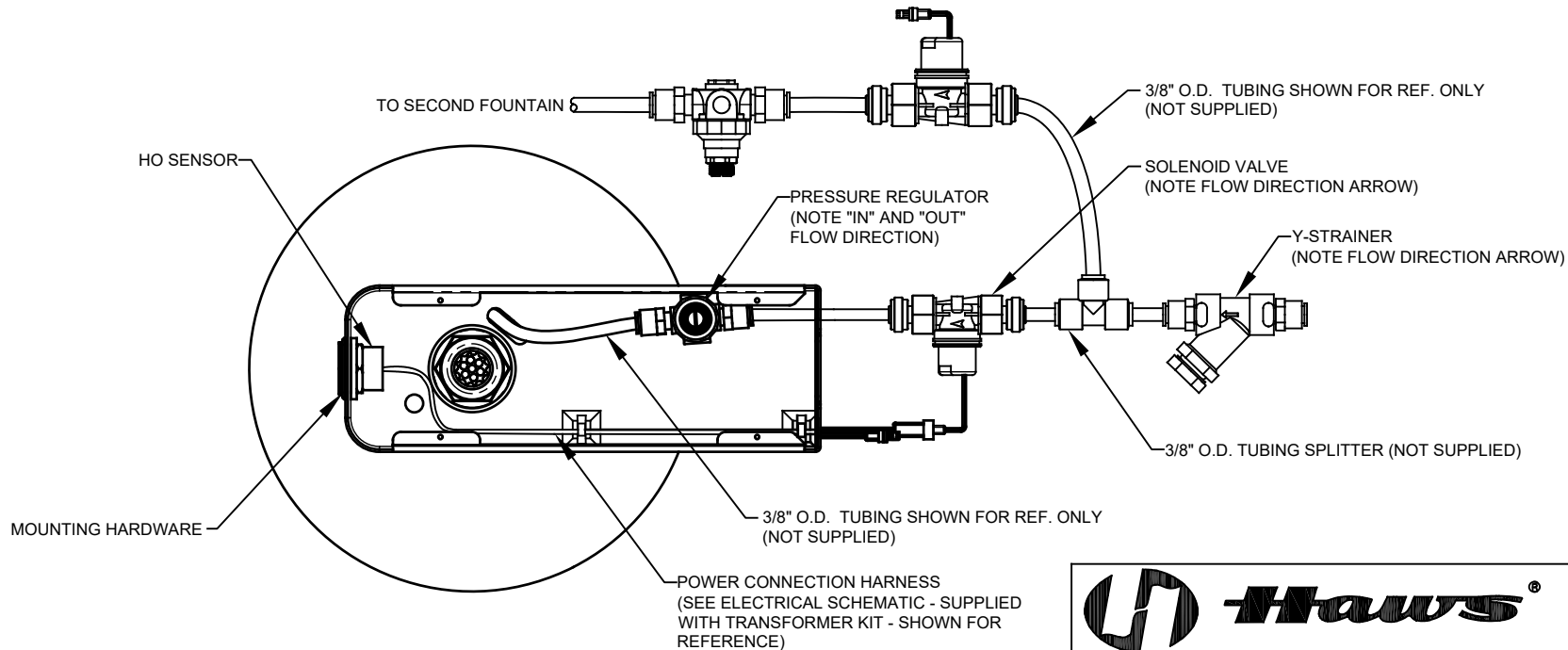

VIEW A - A
(BOTTOM PLATE OMITTED FOR CLARITY)

		1455 KLEPPE LANE SPARKS, NEVADA 89431 (775) 359-4712 FAX (775) 359-7424 E-MAIL: HAWS@HAWSCO.COM WEBSITE: WWW.HAWSCO.COM			
		ECN NO. 5649 DRAWN: BJM APPROVED: DP	REVISED PER: BJM ECN: 5705 DATE: 02/10/21	MODEL(S) 2RKHO.P / 2RKHO.H DUAL HANDS-OFF RETRO-FIT KIT	PART NUMBER 0580001156.D REVISION 3
DATE: 06/15/21	CHKD.: FV	SCALE: N/A	DRAWING TYPE: INSTALLATION	SIZE: A	SHEET 1 OF 4

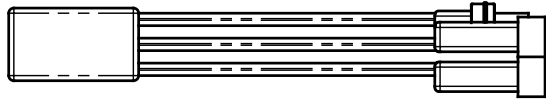

DUAL POWER SPLITTER

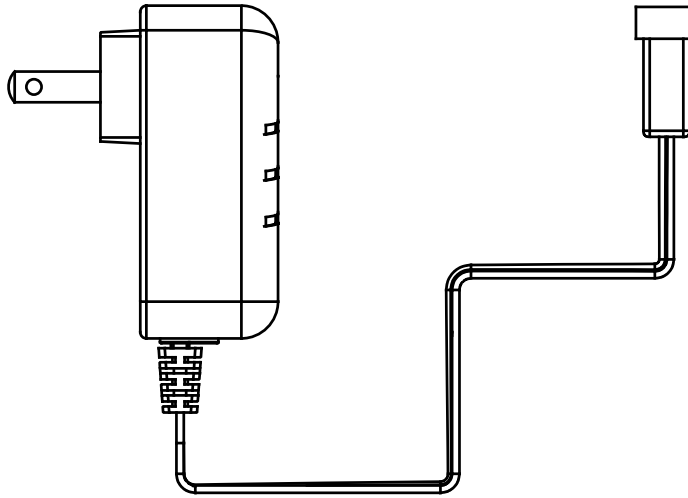

PLUG-IN TRANSFORMER

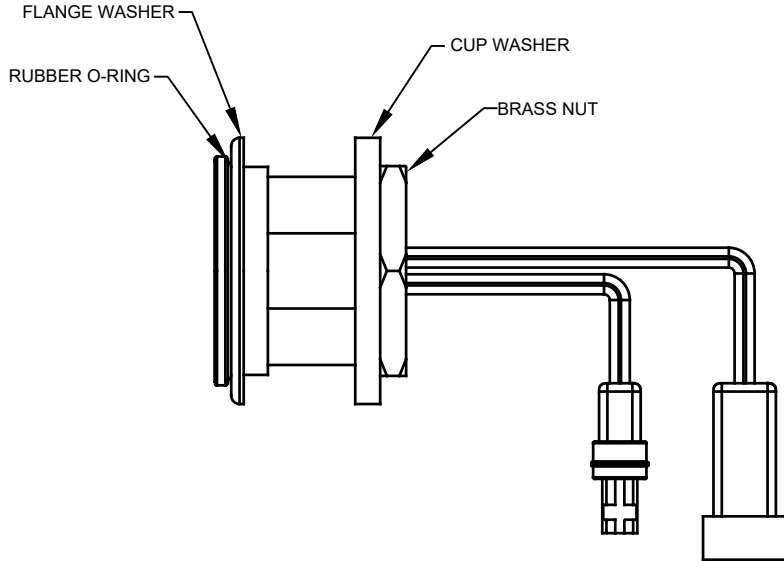

HO SENSOR ASSEMBLY (2X)

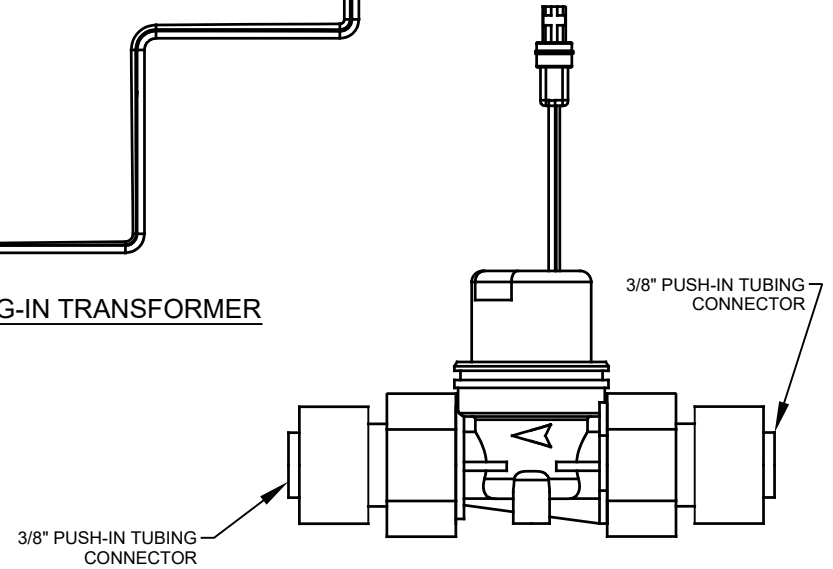

SOLENOID VALVE ASSEMBLY (2X)

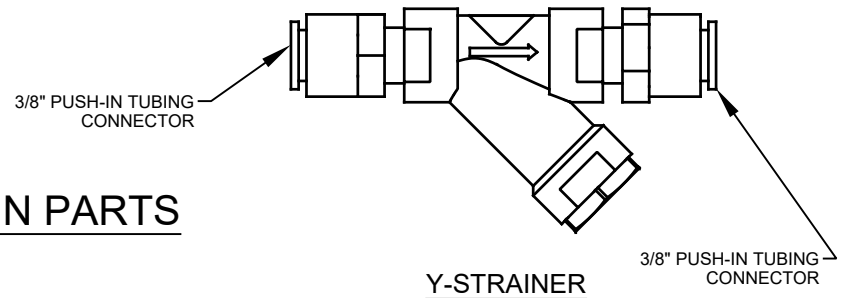

Y-STRAINER

2RKHO.P KIT - MAIN PARTS

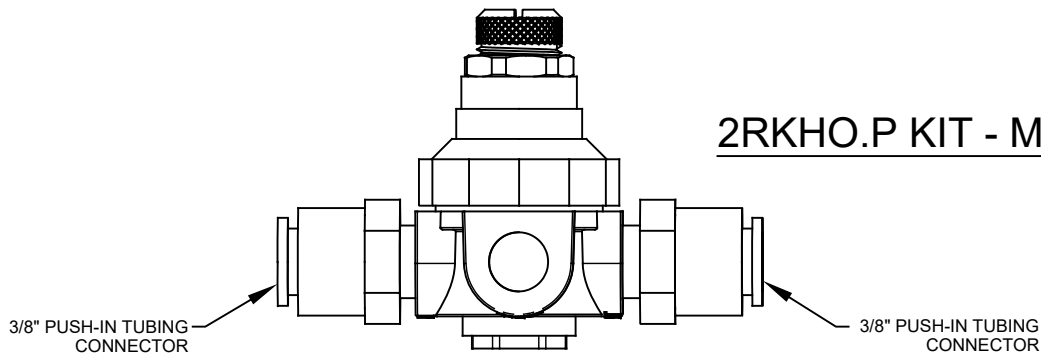

VALVE REGULATOR (2X)

		1455 KLEPPE LANE SPARKS, NEVADA 89431 (775) 359-4712 FAX (775) 359-7424 E-MAIL: HAWS@HAWSCO.COM WEBSITE: WWW.HAWSCO.COM	
ECN NO. 5649	REVISED PER ECN: 5705	BY: BJM	MODEL(S) 2RKHO.P / 2RKHO.H
DRAWN: BJM	DATE: 02/10/21	CHKD.: FV	PART NUMBER 0580001156.D
APPROVED: DP	DATE: 06/15/21	SCALE: N/A	REVISION 3
		DRAWING TYPE: INSTALLATION	SIZE: A SHEET 2 OF 4

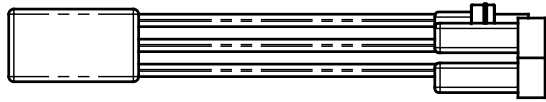

DUAL POWER SPLITTER

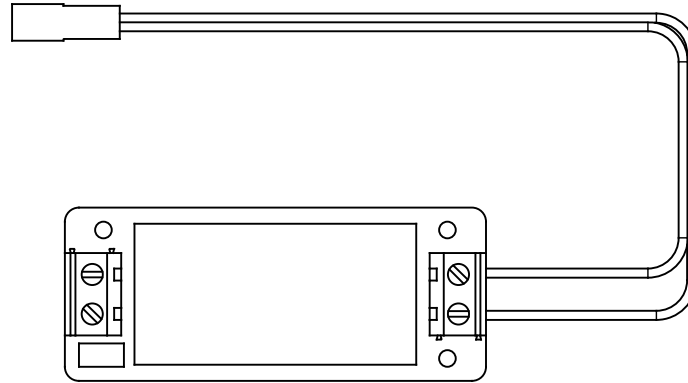

HARDWIRE TRANSFORMER

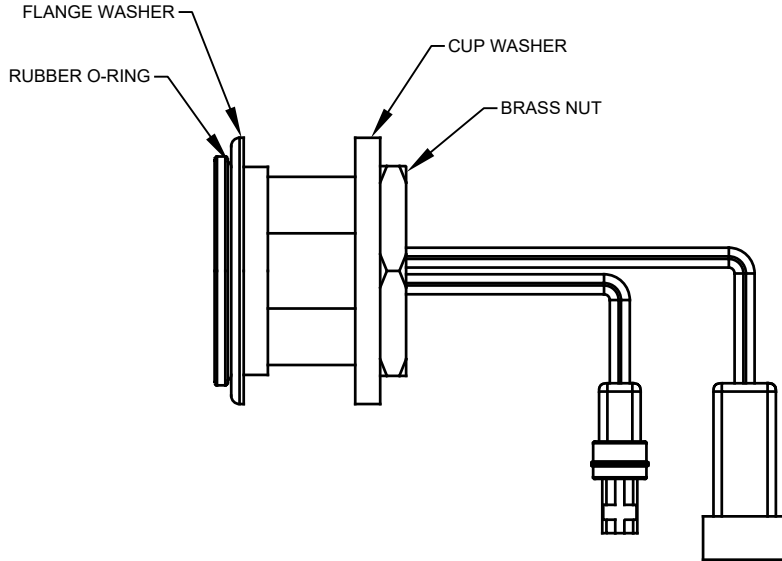

HO SENSOR ASSEMBLY (2X)

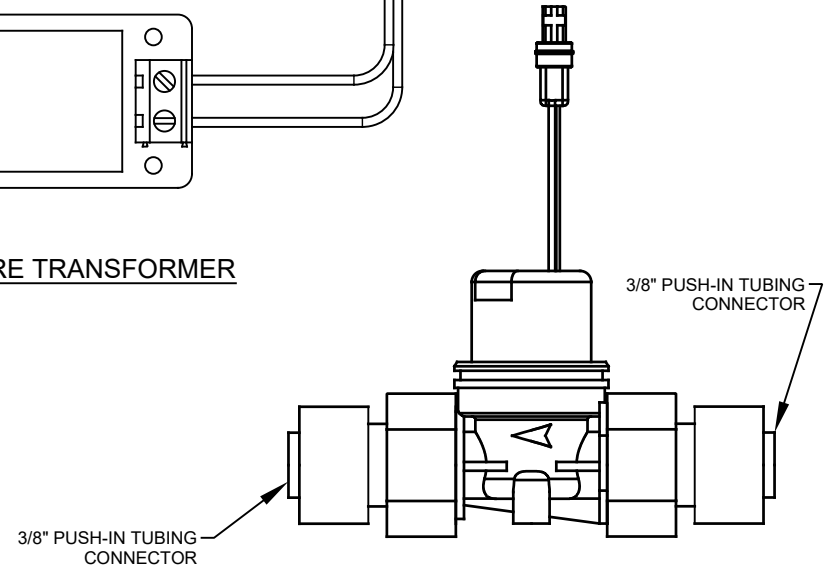

SOLENOID VALVE ASSEMBLY (2X)

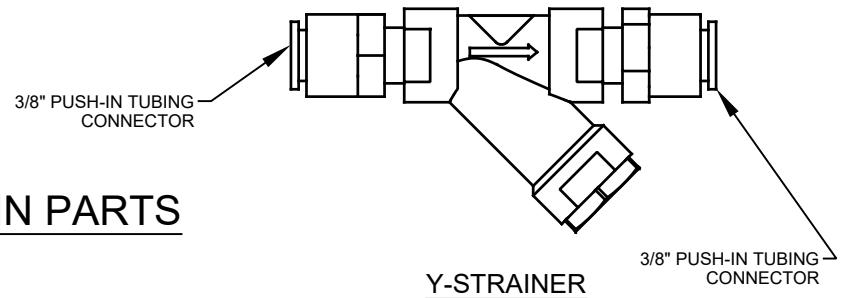

Y-STRAINER

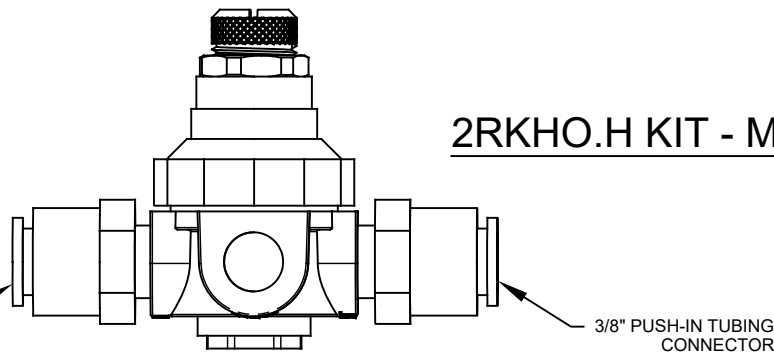

2RKHO.H KIT - MAIN PARTS

VALVE REGULATOR (2X)

		1455 KLEPPE LANE SPARKS, NEVADA 89431 (775) 359-4712 FAX (775) 359-7424 E-MAIL: HAWS@HAWSCO.COM WEBSITE: WWW.HAWSCO.COM	
ECN NO. 5649	REVISED PER ECN: 5705	BY: BJM	MODEL(S) 2RKHO.P / 2RKHO.H
DRAWN: BJM	DATE: 02/10/21	CHKD.: FV	PART NUMBER 0580001156.D
APPROVED: DP	DATE: 06/15/21	SCALE: N/A	REVISION 3
		DRAWING TYPE: INSTALLATION	SIZE: A SHEET 3 OF 4

NOTES (CONTINUED FROM SHEET 1):

- 6. 2RKHO.H TRANSFORMER WIRE RANGE: 24-12 AWG
2RKHO.H TRANSFORMER TIGHTENING TORQUE: MAX 0.4 N*m

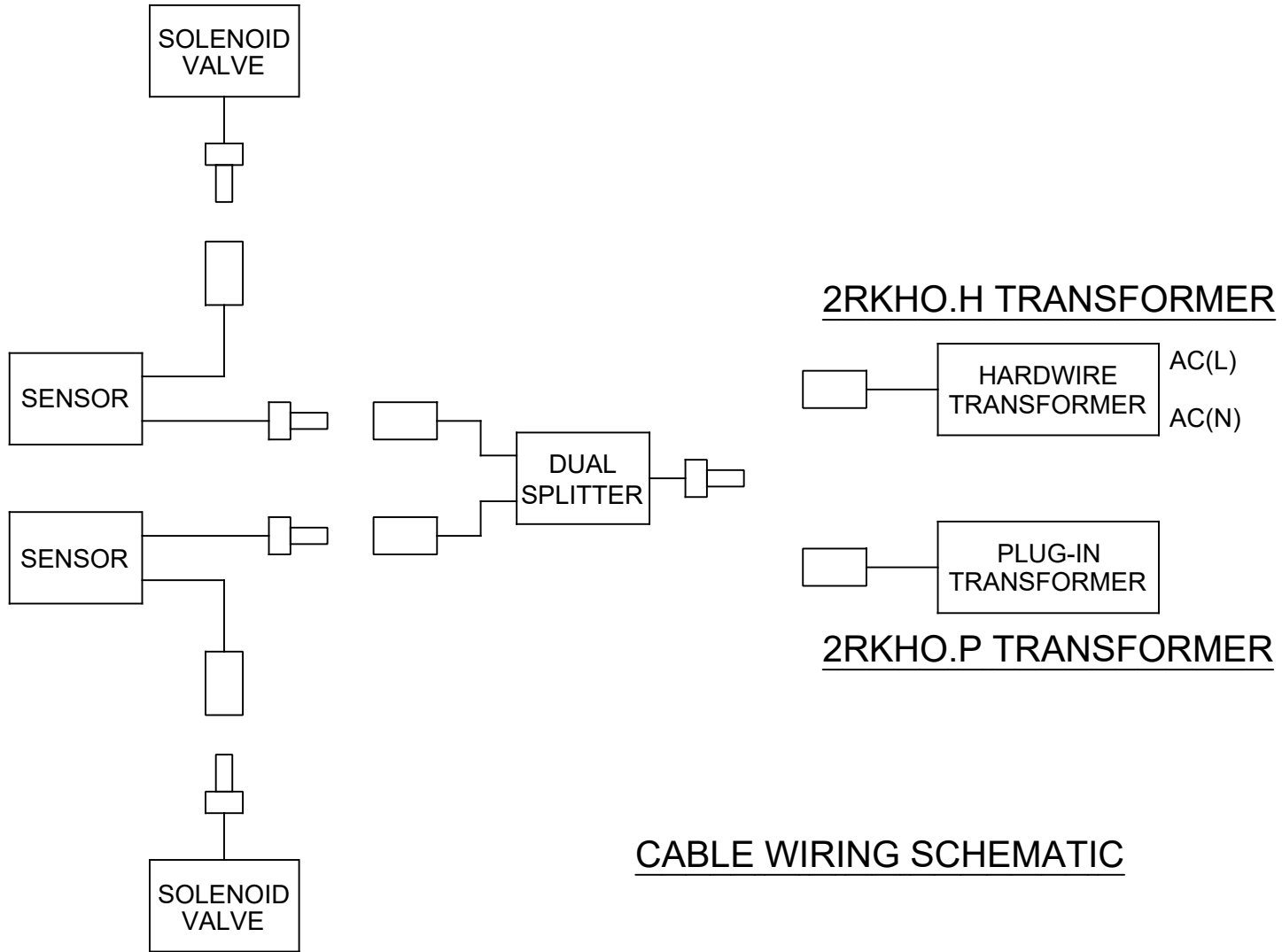

CABLE WIRING SCHEMATIC

		1455 KLEPPE LANE SPARKS, NEVADA 89431 (775) 359-4712 FAX (775) 359-7424 E-MAIL: HAWS@HAWS.CO.COM WEBSITE: WWW.HAWS.CO.COM	
ECN NO. 5649	REVISED PER ECN: 5705	BY: BJM	MODEL(S) 2RKHO.P / 2RKHO.H
DRAWN: BJM	DATE: 02/10/21	CHK'D: FV	DUAL HANDS-OFF RETRO-FIT KIT
APPROVED: DP	DATE: 06/15/21	SCALE: N/A	DRAWING TYPE: INSTALLATION
			PART NUMBER 0580001156.D
			REVISION 3
			SIZE: A SHEET 4 OF 4